



JOHN DEERE

D

EXCAVATORS

75D



Specifications

Engine

Manufacturer and Model	Isuzu 4LE2X
Non-Road Emission Standards	certified to EPA interim Tier 4 emissions
Net Power (ISO9249)	54 hp (40.5 kW) @ 2,000 rpm
Cylinders	4
Displacement	133 cu. in. (2.2 L)
Off-Level Capacity	70% (35 deg.)
Aspiration	turbocharged with intercooler

Cooling

Variable-speed fan directly driven by the engine through a linear clutch; nonreversible

Powertrain

Two-speed propel with automatic shift	
Travel Speed (maximum)	
Low	1.9 mph (3.1 km/h)
High	3.1 mph (5.0 km/h)

Hydraulics

Open center, load sensing	
Main Pumps	3 variable-displacement axial piston
Maximum Rated Flow	2 x 20.9 gpm + 16.3 gpm (2 x 79.2 lpm + 61.6 lpm)
Pilot Pump	one gear
Maximum Rated Flow	5.3 gpm (20 L/m)
System Relief Pressure	566 psi (3900 kPa)
System Operating Pressure	
Implement Circuits	3,771 psi (26 000 kPa)
Travel Circuits	4,554 psi (31 400 kPa)
Swing Circuits	3,626 psi (25 000 kPa)
Controls	pilot levers, short stroke, low effort; hydraulic pilot controls with shutoff lever

Cylinders

Heat-treated, chrome-plated, polished cylinder rods, hardened steel (replaceable bushings) pivot pins			
	<i>Bore</i>	<i>Rod Diameter</i>	<i>Stroke</i>
Boom (1)	4.5 in. (115 mm)	2.6 in. (65 mm)	34.8 in. (885 mm)
Arm (1)	3.7 in. (95 mm)	2.4 in. (60 mm)	35.4 in. (900 mm)
Bucket (1)	3.3 in. (85 mm)	2.2 in. (55 mm)	28.7 in. (730 mm)

Electrical

Batteries	2 x 12 volt
Reserve Capacity	100 min.
Alternator Rating	50 amp
Work Lights	halogen (2), one mounted on boom and one on frame

Undercarriage

Carrier Rollers (per side)	1
Track Rollers (per side)	5
Shoes, Triple Semi-Grouser (per side)	40
Drawbar Pull	14,661 lb. (6650 kg)
Track	
Adjustment	hydraulic
Chain	sealed and lubricated

Swing Mechanism

Swing Speed	10.5 rpm
Swing Torque	12,244 lb.-ft. (16 600 Nm)

Ground Pressure

24-in. (600 mm) Triple Semi-Grouser Shoes	3.7 psi (26 kPa)
18-in. (450 mm) Rubber Crawler Pads	4.9 psi (34 kPa)
18-in. (450 mm) Rubber Crawler Belt	4.9 psi (34 kPa)

Serviceability

Refill Capacities

Fuel Tank	35.7 gal. (135 L)
Cooling System	2.7 gal. (10.3 L)
Engine Oil with Filter	3.2 gal. (12.1 L)
Hydraulic Tank	15 gal. (56 L)
Hydraulic System	26 gal. (100 L)
Propel Gearbox (each)	1.3 qt. (1.2 L)

Operating Weights

With Full Fuel Tank; 175-lb. (79 kg) Operator;	
0.53-cu.-yd. (0.41 m ³), 30-in. (762 mm),	
735-lb. (333 kg) Bucket; 5-ft. 4-in. (1.62 m)	
Arm; 3,049-lb. (1383 kg) Counterweight;	
and 8-ft. 1-in. (2470 mm) Blade	
24-in. (600 mm) Triple Semi-Grouser Shoes	17,743 lb. (8048 kg)
18-in. (450 mm) Rubber Crawler Pads	17,461 lb. (7920 kg)
18-in. (450 mm) Rubber Crawler Belt	17,412 lb. (7898 kg)

Optional Components

Undercarriage	
24-in. (600 mm) Triple Semi-Grouser	
Shoes	3,366 lb. (1527 kg)
18-in. (450 mm) Rubber Crawler Pads	3,036 lb. (1377 kg)
One-Piece Boom (with arm cylinder)	1,025 lb. (465 kg)
Arm with Bucket Cylinder and Linkage	
5 ft. 4 in. (1.62 m)	514 lb. (233 kg)
6 ft. 11 in. (2.12 m)	595 lb. (270 kg)
Boom Lift Cylinder	196 lb. (89 kg)
Counterweight (standard)	3,049 lb. (1383 kg)

Operating Dimensions

	<i>Arm Length</i> 5 ft. 4 in. (1.62 m)	<i>Arm Length</i> 6 ft. 11 in. (2.12 m)
Arm Force	8,554 lb. (38.1 kN)	7,209 lb. (32.1 kN)
Bucket Digging Force	12,368 lb. (55.0 kN)	12,368 lb. (55.0 kN)
Lifting Capacity Over Front at Ground Level		
20-ft. (6.1 m) Reach	4,248 lb. (1927 kg)	4,151 lb. (1883 kg)
A Maximum Reach	21 ft. 1 in. (6.43 m)	22 ft. 8 in. (6.92 m)
A' Maximum Reach at Ground Level	20 ft. 6 in. (6.26 m)	22 ft. 2 in. (6.76 m)
B Maximum Digging Depth	13 ft. 6 in. (4.11 m)	15 ft. 1 in. (4.61 m)
B' Maximum Digging Depth at 8-ft. (2.44 m)		
Flat Bottom	12 ft. 4 in. (3.76 m)	14 ft. 2 in. (4.33 m)
C Maximum Cutting Height	23 ft. 8 in. (7.21 m)	25 ft. 0 in. (7.61 m)
D Maximum Dumping Height	16 ft. 10 in. (5.12 m)	18 ft. 1 in. (5.51 m)
E Minimum Swing Radius	5 ft. 11 in. (1.80 m)	7 ft. 1 in. (2.16 m)
F Maximum Vertical Wall	12 ft. 0 in. (3.67 m)	13 ft. 10 in. (4.22 m)
G Tail Swing Radius	4 ft. 3 in. (1.29 m)	4 ft. 3 in. (1.29 m)

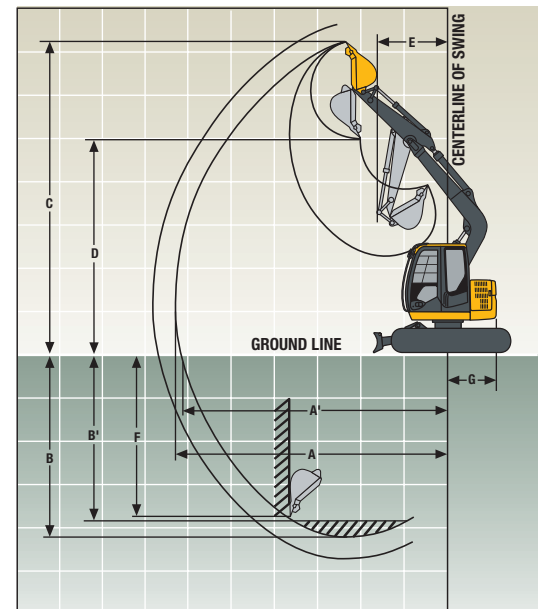

Machine Dimensions

	<i>Arm Length</i> 5 ft. 4 in. (1.62 m)	<i>Arm Length</i> 6 ft. 11 in. (2.12 m)
A Overall Length	20 ft. 8 in. (6.30 m)	20 ft. 11 in. (6.37 m)
B Overall Height	8 ft. 6 in. (2.60 m)	9 ft. 3 in. (2.83 m)
C Overall Width with Blade:		
24-in. (600 mm) Triple Semi-Grouser		
Shoes	8 ft. 1 in. (2.47 m)	
Track Height	26 in. (0.65 m)	
18-in. (450 mm) Rubber Crawler Pads	7 ft. 7 in. (2.32 m)	
18-in. (450 mm) Rubber Crawler Belt	7 ft. 7 in. (2.32 m)	
D Rear-End Length/Swing Radius	4 ft. 3 in. (1.29 m)	
E Distance Between Idler/Sprocket Centerline	7 ft. 6 in. (2.29 m)	
F Undercarriage Length	9 ft. 7 in. (2.92 m)	
G Counterweight Clearance	30 in. (0.76 m)	
H Cab Height	8 ft. 10 in. (2.69 m)	
I Ground Clearance	14 in. (360 mm)	
J Upperstructure Width	7 ft. 5 in. (2.25 m)	
K Gauge Width	6 ft. 2 in. (1.87 m)	
L Blade Lift Height	15 in. (380 mm)	
M Blade Cut Below Grade	11 in. (280 mm)	
N Blade Lift Angle	27 deg.	
Blade Height	18 in. (460 mm)	

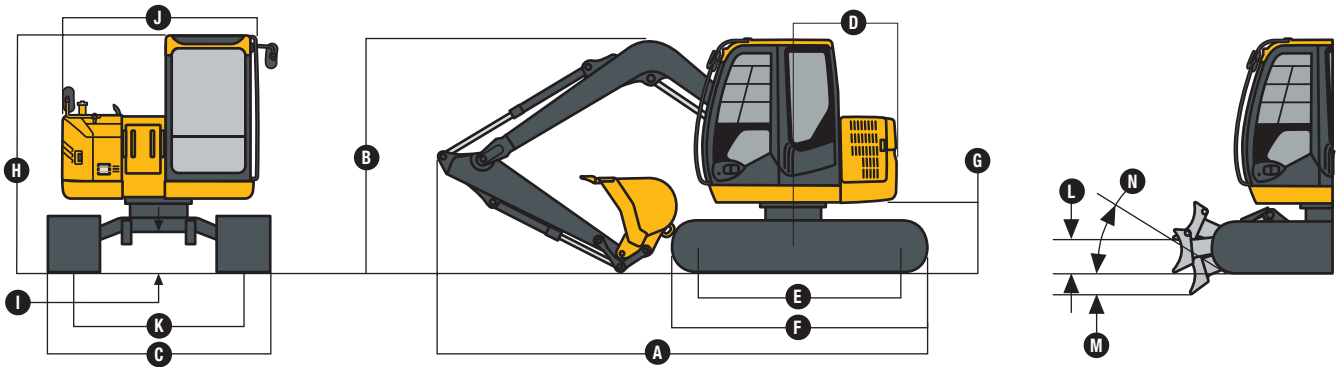

Lift Capacities

Boldface italic type indicates hydraulic-limited capacities; lightface type indicates stability-limited capacities, in lb. (kg). Ratings at bucket lift hook; machine equipped with 12-ft. 8-in. (3.72 m) boom, 0.37-cu.-yd. (0.28 m³) bucket; and situated on firm, uniform supporting surface. Total load includes weight of cables, hook, etc. Figures do not exceed 87 percent of hydraulic capacities or 75 percent of weight needed to tip machine. All lift capacities are based on SAE J1097.

Load Point Height	10 ft. (3.05 m)		15 ft. (4.57 m)		20 ft. (6.10 m)	
	Over Front	Over Side	Over Front	Over Side	Over Front	Over Side
<i>With 5-ft. 4-in. (1.62 m) arm, either 18-in. (450 mm) rubber crawler pads or 18-in. (450 mm) rubber crawler belt, and 7-ft. 7-in. (2.32 m) blade on ground</i>						
10 ft. (3.05 m)	3,821 (1733)	3,821 (1733)	3,265 (1481)	3,163 (1435)		
5 ft. (1.52 m)	6,566 (2978)	5,570 (2527)	4,056 (1840)	2,987 (1355)		
Ground Line	7,676 (3482)	5,286 (2398)	4,709 (2136)	2,842 (1289)		
-5 ft. (-1.52 m)	7,249 (3288)	5,285 (2397)	4,657 (2112)	2,807 (1273)		
-10 ft. (-3.05 m)	5,260 (2386)	5,260 (2386)				
<i>With 6-ft. 11-in. (2.12 m) arm, either 18-in. (450 mm) rubber crawler pads or 18-in. (450 mm) rubber crawler belt, and 7-ft. 7-in. (2.32 m) blade on ground</i>						
15 ft. (4.57 m)			2,464 (1118)	2,464 (1118)		
10 ft. (3.05 m)	2,871 (1302)	2,871 (1302)	2,775 (1259)	2,775 (1259)		
5 ft. (1.52 m)	5,593 (2537)	5,593 (2537)	3,656 (1658)	3,006 (1363)	3,073 (1394)	1,838 (834)
Ground Line	7,400 (3357)	5,285 (2397)	4,479 (2032)	2,824 (1281)	2,816 (1277)	1,776 (806)
-5 ft. (-1.52 m)	7,486 (3396)	5,202 (2360)	4,721 (2141)	2,748 (1246)		
-10 ft. (-3.05 m)	6,187 (2806)	5,312 (2409)				

Lift Capacities (continued)

Boldface italic type indicates hydraulic-limited capacities; lightface type indicates stability-limited capacities, in lb. (kg). Ratings at bucket lift hook; machine equipped with 12-ft. 8-in. (3.72 m) boom, 0.37-cu.-yd. (0.28 m³) bucket; and situated on firm, uniform supporting surface. Total load includes weight of cables, hook, etc. Figures do not exceed 87 percent of hydraulic capacities or 75 percent of weight needed to tip machine. All lift capacities are based on SAE J1097.

Load Point Height	10 ft. (3.05 m)		15 ft. (4.57 m)		20 ft. (6.10 m)	
	Over Front	Over Side	Over Front	Over Side	Over Front	Over Side
<i>With 5-ft. 4-in. (1.62 m) arm, 24-in. (600 mm) triple semi-grouser shoes, and 8-ft. 1-in. (2.47 m) blade on ground</i>						
10 ft. (3.05 m)	3,821 (1733)	3,821 (1733)	3,265 (1481)	3,426 (1554)		
5 ft. (1.52 m)	6,566 (2978)	5,714 (2592)	4,056 (1840)	3,070 (1393)		
Ground Line	7,676 (3482)	5,430 (2463)	4,709 (2136)	2,924 (1326)		
-5 ft. (-1.52 m)	7,249 (3288)	5,429 (2463)	4,657 (2112)	2,890 (1311)		
-10 ft. (-3.05 m)	5,260 (2386)	5,260 (2386)				
<i>With 6-ft. 11-in. (2.12 m) arm, 24-in. (600 mm) triple semi-grouser shoes, and 8-ft. 1-in. (2.47 m) blade on ground</i>						
15 ft. (4.57 m)			2,464 (1118)	2,464 (1118)		
10 ft. (3.05 m)	2,871 (1302)	2,871 (1302)	2,775 (1259)	2,775 (1259)		
5 ft. (1.52 m)	5,593 (2537)	5,593 (2537)	3,656 (1658)	3,089 (1401)	3,073 (1394)	1,896 (860)
Ground Line	7,400 (3357)	5,429 (2463)	4,479 (2032)	2,907 (1319)	2,816 (1277)	1,834 (832)
-5 ft. (-1.52 m)	7,486 (3396)	5,346 (2425)	4,721 (2141)	2,831 (1284)		
-10 ft. (-3.05 m)	6,187 (2806)	5,456 (2475)				

Buckets

A full line of buckets is offered to meet a wide variety of applications. Tooth selection includes either the John Deere Fanggs®, Standard, Tiger, Twin Tiger, Abrasion panel, or Flare tooth, or the ESCO (Vertalok) Standard, Tiger, Twin Tiger, or Flare tooth. Replaceable cutting edges are available through John Deere parts. Optional side cutters add 6 inches (150 mm) to bucket widths.

Type Bucket	Bucket Width		Bucket Capacity*		Weight		Bucket Dig Force		Arm Dig Force 5 ft. 4 in. (1.62 m)		Arm Dig Force 6 ft. 11 in. (2.12 m)		Bucket Tip Radius		No. Teeth
	in.	mm	cu. yd.	m ³	lb.	kg	lb.	kN	lb.	kN	lb.	kN	in.	mm	
Heavy-Duty	24	610	0.40	0.31	633	287	12,061	54.0	8,491	38.0	7,162	32.0	42.80	1087	5
	30	762	0.53	0.41	735	333	12,061	54.0	8,491	38.0	7,162	32.0	42.80	1087	6
	36	914	0.66	0.50	837	380	12,061	54.0	8,491	38.0	7,162	32.0	42.80	1087	7
Ditching	48	1219	0.64	0.49	727	330	14,344	64.0	8,911	40.0	7,473	33.0	35.69	907	0

*All capacities are SAE heaped ratings.

Bucket Selection Guide*

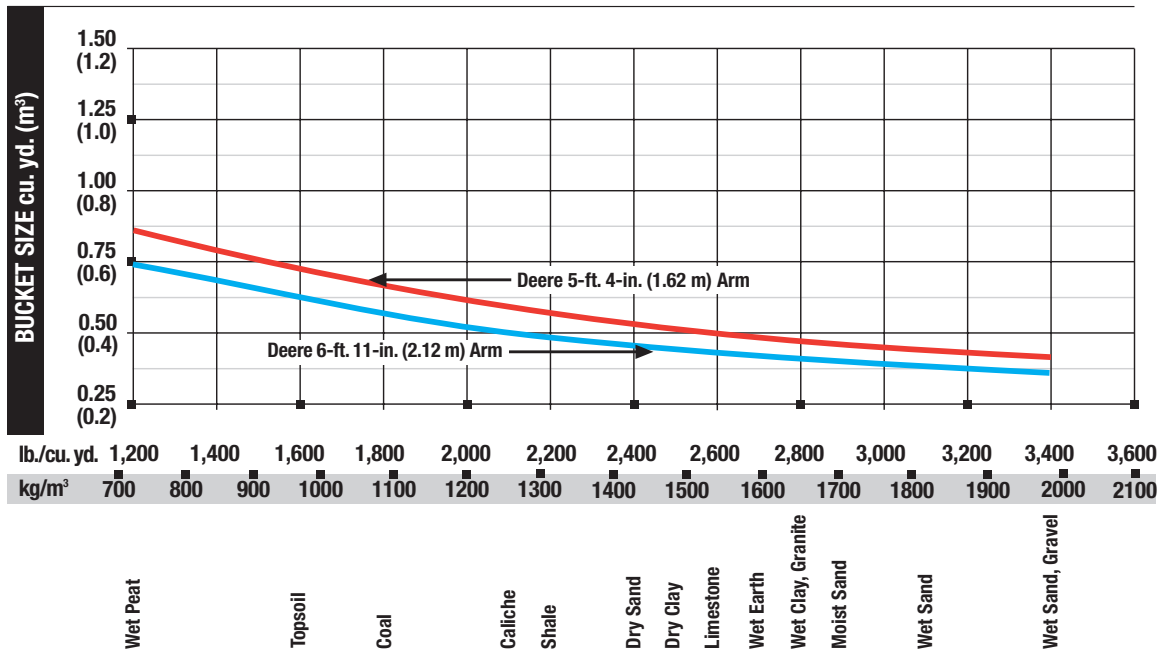

*Contact your John Deere dealer for optimum bucket and attachment selections. These recommendations are for general conditions and average use. Does not include optional equipment such as thumbs or couplers. Larger buckets may be possible when using light materials, for flat and level operations, less compacted materials, and volume loading applications such as mass excavation applications in ideal conditions. Smaller buckets are recommended for adverse conditions such as off-level applications, rocks, and uneven surfaces. Bucket capacity indicated is SAE heaped.

75D EXCAVATOR

Key: ● Standard equipment ▲ Optional or special equipment

See your John Deere dealer for further information.

75D	Engine	75D	Undercarriage (continued)	75D	Operator's Station (continued)
●	Certified to EPA interim Tier 4 emissions	●	Undercarriage with blade	●	Interior light
●	Auto-idle system	▲	Rubber crawler pads, 18-in. (450 mm)	●	Large cup holder
●	Batteries (two 12 volt), 100-min. reserve capacity	▲	Rubber belt, continuous, 18-in. (450 mm)	●	Machine Information Center (MIC)
●	Coolant recovery tank		Upperstructure	●	Mode selectors (illuminated): Power modes – two / Travel modes – two with automatic shift / Work mode – one
●	Dual-element dry-type air filter	●	Counterweight, 3,049 lb. (1383 kg)	●	Multifunction, color LCD monitor with: Diagnostic capability / Multiple-language capabilities / Maintenance tracking / Clock / System monitoring with alarm features: Auto-idle indicator, engine air cleaner restriction indicator light, engine check, engine coolant temperature indicator light with audible alarm, engine oil pressure indicator light with audible alarm, low-alternator-charge indicator light, low-fuel indicator light, fault-code alert indicator, fuel-rate display, wiper-mode indicator, work-lights-on indicator, and work-mode indicator
●	Electronic engine control	●	Right- and left-hand mirrors	●	Motion alarm with cancel switch (conforms to SAE J994)
●	Enclosed fan guard (conforms to SAE J1308)	●	Vandal locks with ignition key: Cab door / Engine hood / Fuel cap / Service doors	●	Auxiliary hydraulic control switches in right console lever
●	Engine coolant to –34 deg. F (–37 deg. C)	●	Remote-mounted engine oil and fuel filters	●	SAE two-lever control pattern
●	Fuel filter with water separator		Front Attachments	●	Seat belt, 2 in. (51 mm), retractable
●	Full-flow oil filter	●	Centralized lubrication system	●	Tinted glass
●	Turbocharger with charge air cooler	●	Dirt seals on all bucket pins	●	Transparent tinted overhead hatch
●	Muffler, under hood, with vertical curved end exhaust stack	●	Less boom and arm	●	Hot/cold beverage compartment
●	Radiator, oil cooler, and intercooler with dust-protective net	●	Oil-impregnated bushings	▲	Seat belt, 3 in. (76 mm), non-retractable
●	Glow-plug start aid	●	Reinforced resin thrust plates	▲	Monitor system with alarm features: Hydraulic oil filter restriction indicator light
●	500-hour engine oil-change interval	●	Tungsten carbide thermal coating on arm-to-bucket joint	▲	24- to 12-volt D.C. radio converters, 10 amp
●	70% (35 deg.) off-level capacity	▲	Arm, 5 ft. 4 in. (1.62 m)	▲	Circulation fan
●	Isolation mounted	▲	Arm, 6 ft. 11 in. (2.12 m)	▲	Protection screens for cab front, rear, and side
●	Engine oil-drain coupler	▲	Attachment quick-couplers	▲	Window vandal protection covers
	Hydraulic System	▲	Buckets: Ditching / Heavy duty / Heavy-duty high capacity / Side cutters and teeth		Electrical
●	Reduced-drift valve for boom down, arm in	▲	Material clamps	●	50-amp alternator
●	Auxiliary hydraulic valve section		Operator's Station	●	Blade-type multi-fused circuits
●	Spring-applied, hydraulically released automatic swing brake	●	Adjustable independent control positions (seat-to-pedals)	●	Positive terminal battery covers
●	Auxiliary hydraulic-flow adjustments through monitor	●	AM/FM radio	▲	JDLink™ wireless communication system
●	5,000-hour hydraulic oil-change interval	●	Auto climate control/air conditioner, 20,000 Btu/hr. (5.9 kW), with heater and pressurizer		Lights
▲	Auxiliary hydraulic lines	●	Built-in operator's manual storage compartment and manual	●	Work lights: Halogen / One mounted on boom / One mounted on frame
▲	Auxiliary pilot and electric controls	●	Cell-phone power outlet, 12 volt, 60 watt, 5 amp		
▲	Hydraulic filter restriction indicator kit	●	Coat hook		
▲	Load-lowering control device	●	Deluxe suspension cloth seat with 4-in. (100 mm) adjustable armrests		
▲	Single-pedal propel control	●	Floor mat		
▲	Control pattern-change valve	●	Front windshield wiper with intermittent speeds		
	Undercarriage	●	Gauges (illuminated): Engine coolant / Fuel		
●	Planetary drive with axial piston motors	●	Horn, electric		
●	Propel motor shields	●	Hour meter, electric		
●	Spring-applied, hydraulically released automatic propel brake	●	Hydraulic shutoff lever, all controls		
●	Track guides, front idler	●	Hydraulic warm-up control		
●	Two-speed propel with automatic shift				
●	Upper carrier roller (1)				
●	Sealed and lubricated track chain				
●	Triple semi-grouser shoes, 24 in. (600 mm)				

CONTROL OWNING AND OPERATING COSTS

Customer Personal Service (CPS) is part of John Deere's proactive, fix-before-fail strategy on machine maintenance that will help control costs, increase profits, and reduce stress. Included in this comprehensive lineup of ongoing programs and services are:

Fluid analysis program – tells you what's going on inside *all* of your machine's major components so you'll know if there's a problem *before* you see a decline in performance. Fluid analysis is included in most extended coverage and preventive-maintenance agreements.

Component life-cycle data – gives you vital information on the projected life span of components and lets you make informed decisions on machine maintenance by telling you approximately how many hours of use you can expect from an engine, transmission, or hydraulic pump. This information can be used to preempt catastrophic downtime by servicing major components at about 80 percent of their life cycle.

Preventive Maintenance (PM) agreements – give you a fixed cost for maintaining a machine for a given period of time. They also help you avoid downtime by ensuring that

critical maintenance work gets done right and on schedule. On-site preventive maintenance service performed where and when you need it helps protect you from the expense of catastrophic failures and lets you avoid waste-disposal hassles.

Extended coverage – gives you a fixed cost for machine repairs for a given period of time so you can effectively manage costs. Whether you work in a severe-service setting or just want to spread the risk of doing business, this is a great way to custom-fit coverage for your operation. And an extended coverage contract also travels well because it's backed by John Deere and is honored by *all* Deere construction dealers.

Customer Support Advisors (CSAs) – Deere believes the CSA program lends a *personal* quality to Customer Personal Service (CPS). Certified CSAs have the knowledge and skills for helping make important decisions on machine maintenance and repair. Their mission is to help you implement a plan that's right for *your* business and take the burden of machine maintenance off your shoulders.



JOHN DEERE

DKAX75D85D Litho in U.S.A. (08-08)

Net engine power is with standard equipment including air cleaner, exhaust system, alternator, and cooling fan at test conditions specified per ISO9249. No derating is required up to 10,000-ft. (3050 m) altitude.

Specifications and design subject to change without notice. Wherever applicable, specifications are in accordance with SAE standards. Except where otherwise noted, these specifications are based on a unit with standard equipment; 0.53-cu.-yd. (0.41 m³), 30-in. (762 mm), 735-lb. (333 kg) bucket; 24-in. (600 mm) triple semi-grouser shoes; 5-ft. 4-in. (1.62 m) arm; full fuel tank; and 175-lb. (79 kg) operator; and 3,049-lb. (1383 kg) counterweight.

