

35D



Engine		35D			
Manufacturer and Model	Yanmar 3TNV88				
Non-Road Emissions Standard	EPA Interim Tier 4/EU Stage IIIB				
Displacement	1.606 L (100.4 cu. in.)				
Net Power (ISO 9249)	21.3 kW (28.6 hp) at 2,400 rpm				
Powertrain		Each track independently driven by hydrostatic axial-piston motor connected to 2-stage planetary gear-reduction box			
Travel Speed (maximum)					
Low	2.8 km/h (1.7 mph)				
High	4.4 km/h (2.8 mph)				
Swing Speed	9.0 rpm				
Swing Brake	Spring applied, hydraulically released, automatic, disc type				
Hydraulics		Open center with 2 variable-displacement pumps and 1 fixed-gear pump			
Pump Flow					
Piston	2 x 40.1 L/m (2 x 10.6 gpm)				
Gear	26.1 L/m (6.9 gpm)				
Auxiliary Flow	66.2 L/m (17.5 gpm)				
Controls	Hydraulic pilot-operated for boom, arm, bucket, swing, boom swing, blade, and travel				
Electrical					
Alternator Rating	55 amp				
Work Lights	2 halogen: 1 mounted on operator's station and 1 mounted on boom				
Undercarriage		2-speed axial-piston propel motors			
Tracks, Rubber		300 mm (12 in.)			
Ground Pressure					
	<i>1.35-m (4 ft. 4 in.) Standard Arm, Canopy, and Standard Counterweight</i>	<i>1.35-m (4 ft. 4 in.) Standard Arm, Cab, and Standard Counterweight</i>	<i>1.75-m (5 ft. 8 in.) Long Arm, Canopy, and Extra Counterweight</i>	<i>1.75-m (5 ft. 8 in.) Long Arm, Cab, and Extra Counterweight</i>	
With Rubber Track	31.7 kPa (4.60 psi)	33.1 kPa (4.80 psi)	35.0 kPa (5.08 psi)	38.1 kPa (5.53 psi)	
Upperstructure					
Independent Swing Boom					
Left	72 deg. canopy / 62 deg. cab				
Right	62 deg. canopy or cab				
Counterweight					
Standard	566 kg (1,246 lb.)				
Additional	235 kg (518 lb.)				
Serviceability					
Refill Capacities					
Fuel Tank	40 L (10.6 gal.)				
Cooling System	5.0 L (5.3 qt.)				
Engine Oil with Filter	7.2 L (7.6 qt.)				
Hydraulic Tank	32 L (8.5 gal.)				
Operating Weights					
	<i>1.35-m (4 ft. 4 in.) Standard Arm, Canopy, and Standard Counterweight</i>	<i>1.35-m (4 ft. 4 in.) Standard Arm, Cab, and Standard Counterweight</i>	<i>1.75-m (5 ft. 8 in.) Long Arm, Canopy, and Extra Counterweight</i>	<i>1.75-m (5 ft. 8 in.) Long Arm, Cab, and Extra Counterweight</i>	
With Full Fuel Tank and 79-kg (175 lb.) Operator	3520 kg (7,760 lb.)	3690 kg (8,135 lb.)	3778 kg (8,329 lb.)	3948 kg (8,704 lb.)	



Operating Dimensions		35D			
		1.35-m (4 ft. 4 in.) Standard Arm, Canopy, and Standard Counterweight	1.35-m (4 ft. 4 in.) Standard Arm, Cab, and Standard Counterweight	1.75-m (5 ft. 8 in.) Long Arm, Canopy, and Extra Counterweight	1.75-m (5 ft. 8 in.) Long Arm, Cab, and Extra Counterweight
A	Maximum Digging Height	4.87 m (16 ft. 0 in.)	4.71 m (15 ft. 5 in.)	4.95 m (16 ft. 3 in.)	4.76 m (15 ft. 7 in.)
B	Maximum Dumping Height	3.47 m (11 ft. 5 in.)	3.32 m (10 ft. 11 in.)	3.57 m (11 ft. 9 in.)	3.39 m (11 ft. 1 in.)
C	Maximum Digging Depth	3.05 m (10 ft. 0 in.)	3.05 m (10 ft. 0 in.)	3.45 m (11 ft. 4 in.)	3.45 m (11 ft. 4 in.)
D	Maximum Digging Reach	5.21 m (17 ft. 1 in.)	5.21 m (17 ft. 1 in.)	5.52 m (18 ft. 1 in.)	5.52 m (18 ft. 1 in.)
E	Minimum Front Swing Radius	2.07 m (6 ft. 9 in.)	2.23 m (7 ft. 4 in.)	2.17 m (7 ft. 1 in.)	2.30 m (7 ft. 7 in.)
F	Transport Length	4.65 m (15 ft. 3 in.)	4.65 m (15 ft. 3 in.)	4.78 m (15 ft. 8 in.)	4.78 m (15 ft. 8 in.)
Breakout Force					
	Bucket	27.5 kN (6,182 lb.)	27.5 kN (6,182 lb.)	27.5 kN (6,182 lb.)	27.5 kN (6,182 lb.)
	Arm	19.1 kN (4,294 lb.)	19.1 kN (4,294 lb.)	17.2 kN (3,866 lb.)	17.2 kN (3,866 lb.)

Machine Dimensions		
	Blade Width	1.74 m (5 ft. 9 in.)
	Blade Height	370 mm (14.6 in.)
G	Upperstructure Width	1.55 m (5 ft. 1 in.)
H	Overall Height	
	Canopy	2.46 m (8 ft. 1 in.)
	Cab	2.50 m (8 ft. 2 in.)
I	Track Width	300 mm (12 in.)
J	Undercarriage Width	1.74 m (5 ft. 9 in.)
K	Ground Clearance	280 mm (11 in.)
L	Tail Swing Radius	
	Standard Arm	870 mm (34 in.)
	Long Arm with Extra Counterweight	960 mm (3 ft. 2 in.)
M	Engine Cover Height	1.42 m (4 ft. 8 in.)
N	Maximum Blade Lift Above Ground	370 mm (14.6 in.)
O	Maximum Blade Drop Below Ground	390 mm (15.4 in.)
P	Sprocket Center To Idler Center	1.65 m (5 ft. 5 in.)
Q	Track Length	2.11 m (6 ft. 11 in.)
R	Counterweight Clearance	550 mm (22 in.)

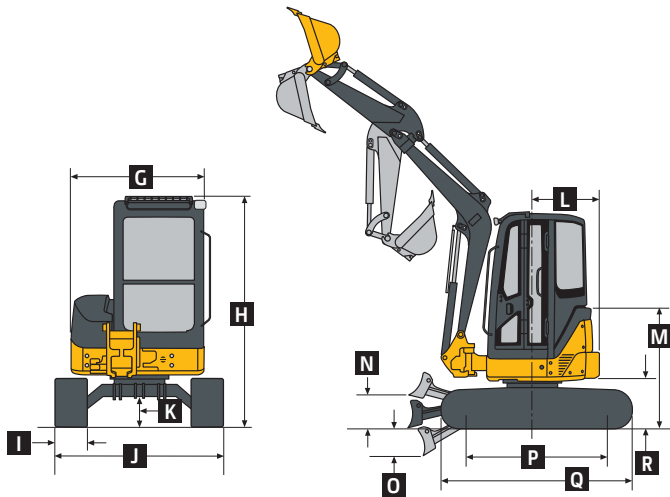
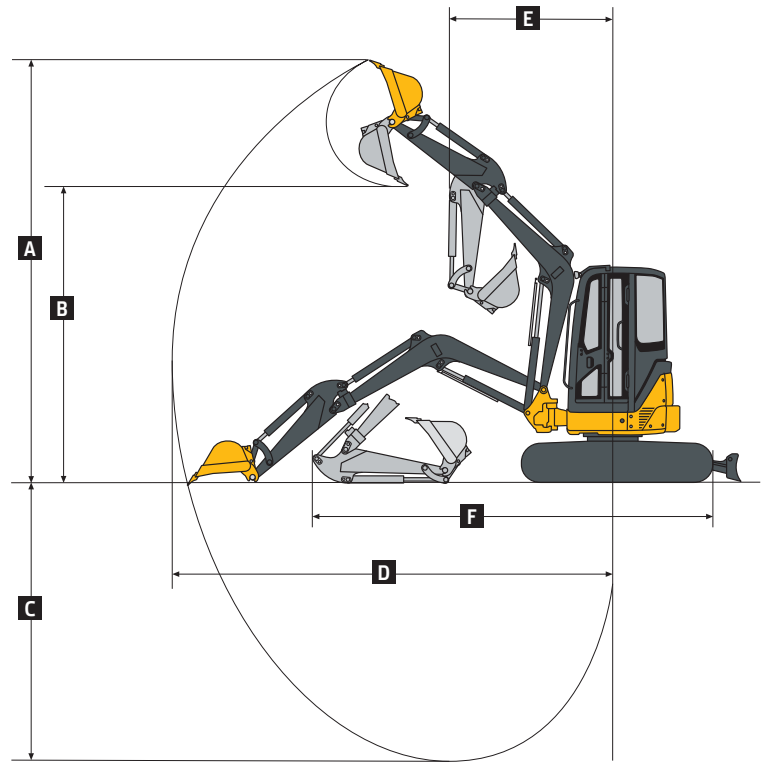

Lift Capacities		35D			
Ground Level at 3.05-m (10 ft.) Radius		1.35-m (4 ft. 4 in.) Standard Arm and Canopy	1.35-m (4 ft. 4 in.) Standard Arm and Cab	1.75-m (5 ft. 8 in.) Long Arm and Canopy	1.75-m (5 ft. 8 in.) Long Arm and Cab
	Over Front, Blade Down (limited by hydraulics), Standard or Extra Counterweight	1505 kg (3,315 lb.)	1505 kg (3,315 lb.)	1422 kg (3,133 lb.)	1422 kg (3,133 lb.)
	Over Side				
	Standard Counterweight	653 kg (1,439 lb.)	688 kg (1,516 lb.)	648 kg (1,428 lb.)	683 kg (1,505 lb.)
	Extra Counterweight	775 kg (1,708 lb.)	775 kg (1,708 lb.)	770 kg (1,697 lb.)	805 kg (1,773 lb.)